

**PAPER TRAY UNIT**  
**(Machine Code: B456)**

# 1. REPLACEMENT AND ADJUSTMENT

**⚠ CAUTION**  
 Turn off the main power switch and unplug the machine before beginning any of the procedures in this section.

**NOTE:** This manual uses the following symbols.

- ☛ : See or Refer to    
 🔩 : Screws    
 🔌 : Connector    
 🔗 : Clip ring  
Ⓢ : E-ring

## 1.1 REAR COVER

1. Joint brackets [A] (🔩 x 1 each)
2. Rear cover [B] (🔩 x 2)

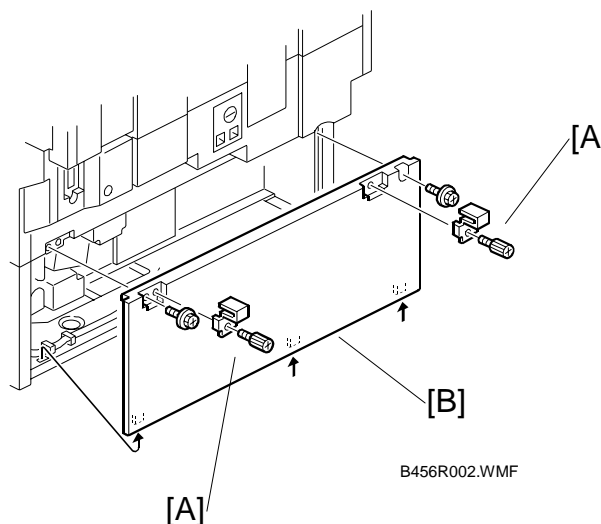

## 1.2 PAPER FEED CLUTCHES

1. Rear cover (☛ 1.1)
2. Brackets [A][B] (🔩 x 1)
3. Clutches [C][D] (1 bearing, 🔌 x 1)

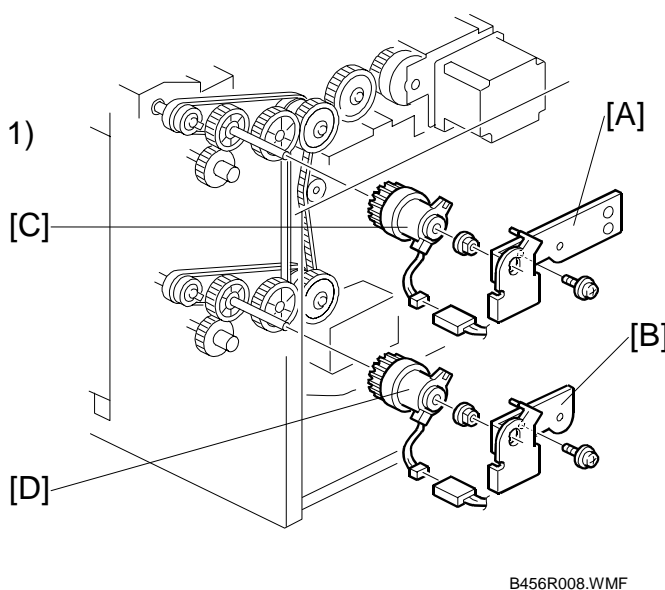

Peripherals

### 1.3 LIFT MOTORS

1. Rear cover (☛ 1.1)
2. Lift motors [A][B] (⚙️ x 2, 📏 x 1)

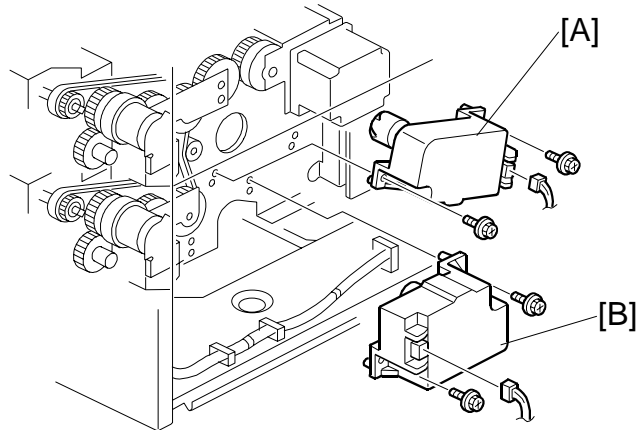

B456R005.WMF

### 1.4 PAPER FEED MOTOR

1. Rear cover (☛ 1.1)
2. Paper feed motor [A] (📏 x 1, ⚙️ x 3)

**NOTE:** Remove the motor with its bracket, then separate the motor from the bracket.

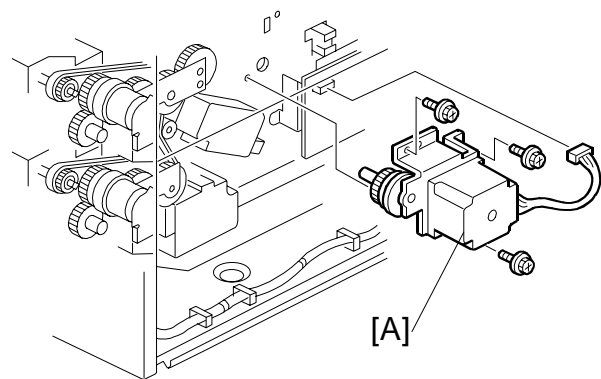

B456R007.WMF

### 1.5 CONTROLLER BOARD

1. Rear cover (☛ 1.1)
2. Controller board [A] (📏 x 7, ⚙️ x 2)

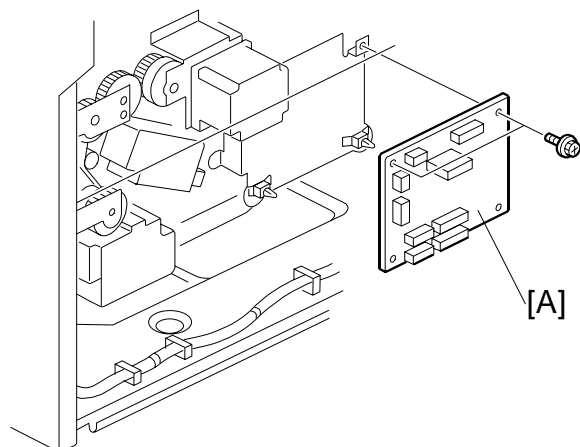

B456R006.WMF

## 1.6 PAPER FEED UNIT

1. Vertical transport guide plate of the copier [A] (🔩 x 1)
2. Vertical transport guide plate of the paper feed unit [B]

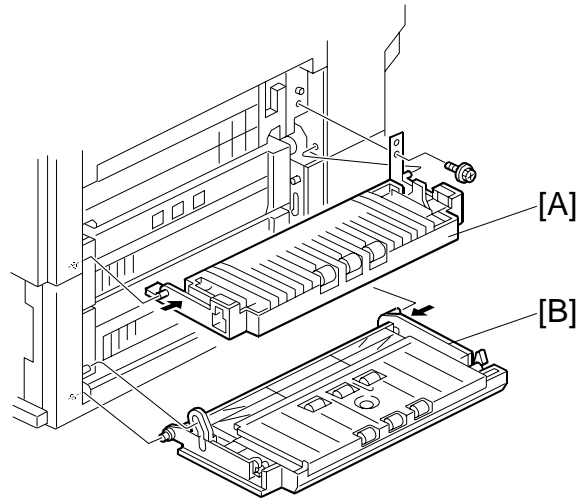

B456R001.WMF

3. Paper feed clutch (🔩 1.2)
4. Gears [C], [D]
5. 📁 x 1 [E]

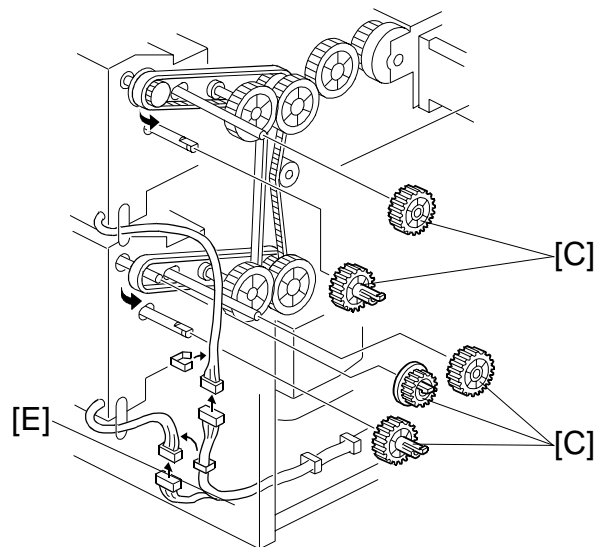

B456R003.WMF

6. Paper feed unit [F] (🔩 x 2)

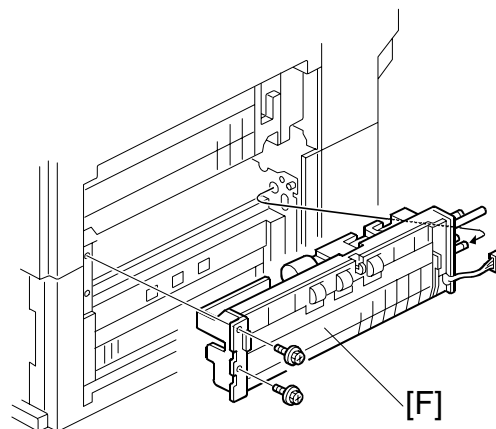

B456R004.WMF

Peripherals

## 1.7 PICKUP, FEED, AND SEPARATION ROLLERS

1. Paper tray [A]
2. Pickup roller [B] (1 hook)
3. Paper feed roller [C] (⌀ x 1)
4. Separation roller [D] (⌀ x 1)

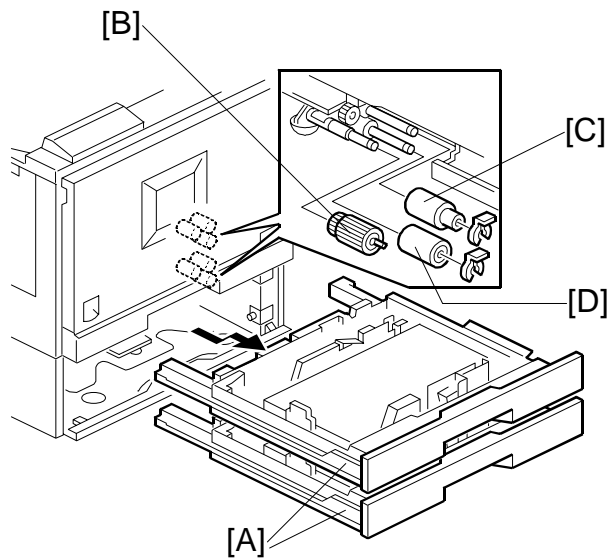

B456R009.WMF

## 1.8 UPPER LIMIT, PAPER END, AND RELAY SENSORS

1. Paper feed unit (☛ 1.6)
2. Relay sensor bracket [A] (⚙ x 1)
3. Relay sensor [B]
4. While pushing the release lever [C], remove the following:
  - Upper limit sensor [D]
  - Paper end sensor [E].

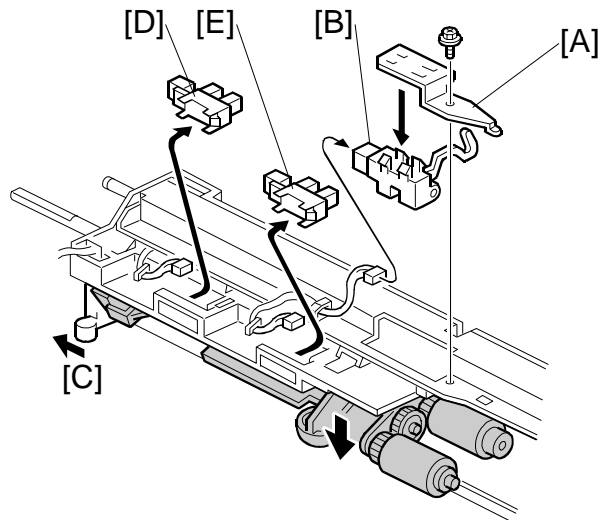

B456R113.WMF

## 2. DETAILED DESCRIPTIONS

### 2.1 MECHANICAL COMPONENT LAYOUT

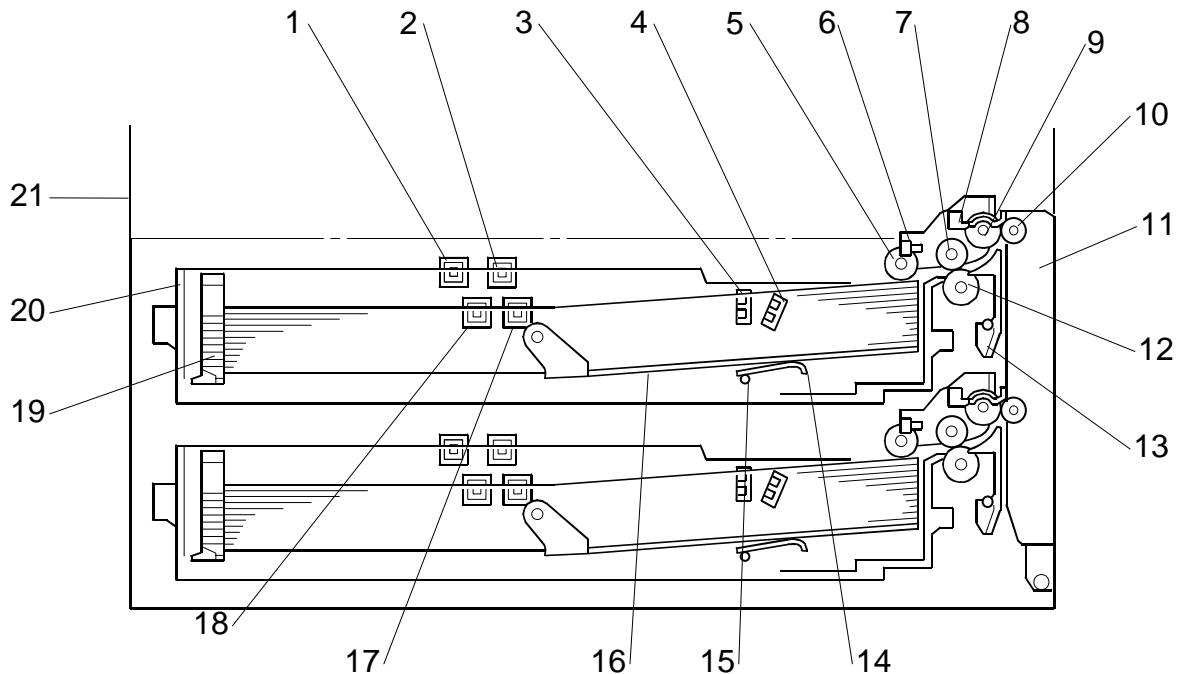

B456D001.WMF

- |                          |                         |
|--------------------------|-------------------------|
| 1. Paper size switch 1   | 12. Reverse roller      |
| 2. Paper size switch 3   | 13. Paper guide         |
| 3. Paper height sensor 1 | 14. Tray lift arm       |
| 4. Paper height sensor 2 | 15. Lift arm shaft      |
| 5. Pickup roller         | 16. Bottom plate        |
| 6. Paper end sensor      | 17. Paper size switch 4 |
| 7. Feed roller           | 18. Paper size switch 2 |
| 8. Relay sensor          | 19. End plate           |
| 9. Relay roller          | 20. Tray                |
| 10. Idle roller          | 21. Copier              |
| 11. Right cover          |                         |

**NOTE:** Listed above are the components of tray 1 (upper tray). Tray 2 (lower tray) has the same components as tray 1.

## 2.2 ELECTRICAL COMPONENT LAYOUT

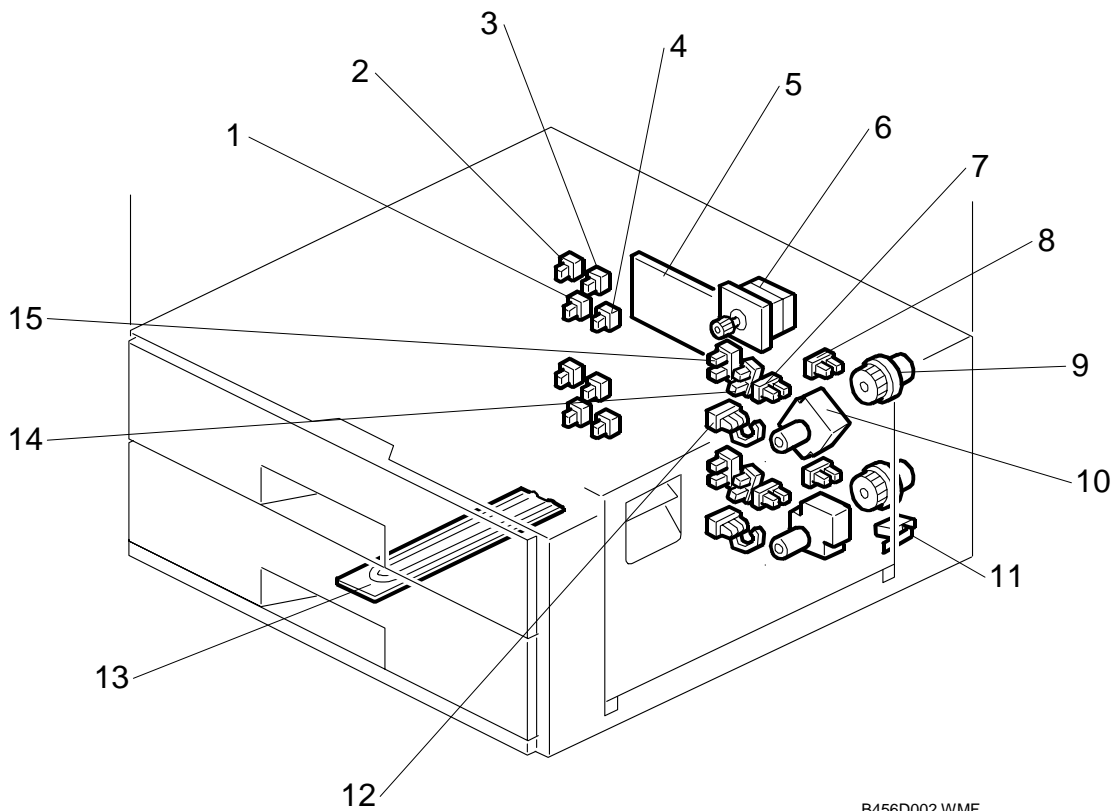

B456D002.WMF

- |                        |   |
|------------------------|---|
| 1. Paper size switch 2 | 9. Paper feed clutch                    |
| 2. Paper size switch 1 | 10. Tray lift motor                     |
| 3. Paper size switch 3 | 11. Right cover switch                  |
| 4. Paper size switch 4 | 12. Relay sensor                        |
| 5. Main board          | 13. Anti-condensation heater (Optional) |
| 6. Paper feed motor    | 14. Paper height sensor 2               |
| 7. Paper end sensor    | 15. Paper height sensor 1               |
| 8. Upper limit sensor  |   |

**NOTE:** Listed above are the components of tray 1 (upper tray), except for the right cover switch and anti-condensation heater (there is only one each of these for the entire unit). Tray 2 (lower tray) has the same components as tray 1.

## 2.3 PAPER FEED

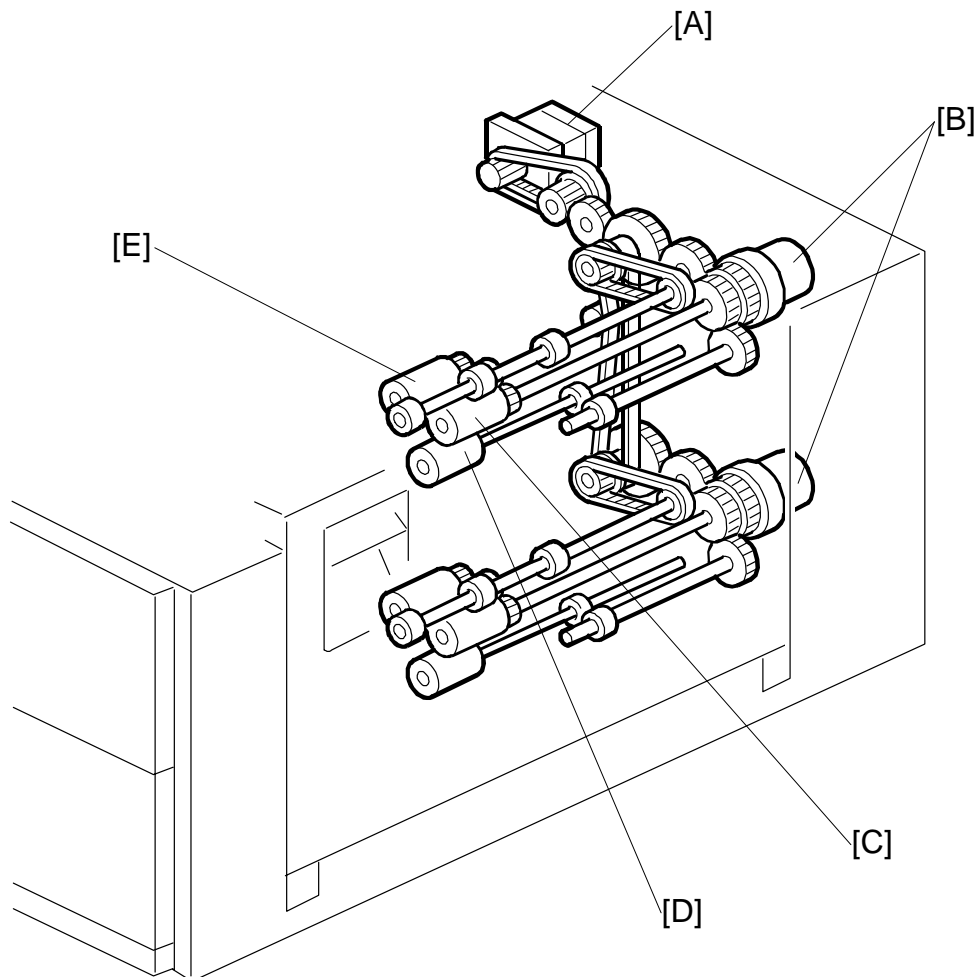

B456D004.WMF

### ***Paper Feed Mechanism***

An FRR (feed and reverse roller) feed mechanism is used (☛ **CT** *Paper Feed Methods*).

### ***Drive Path***

Tray 1 (upper tray) and tray 2 (lower tray) have identical paper feed systems. The paper feed motor [A] drives all the rollers in the unit. The paper feed clutches [B] control the pickup roller [E], paper feed roller [C], and reverse roller [D].



## 2.4 PAPER SIZE DETECTION

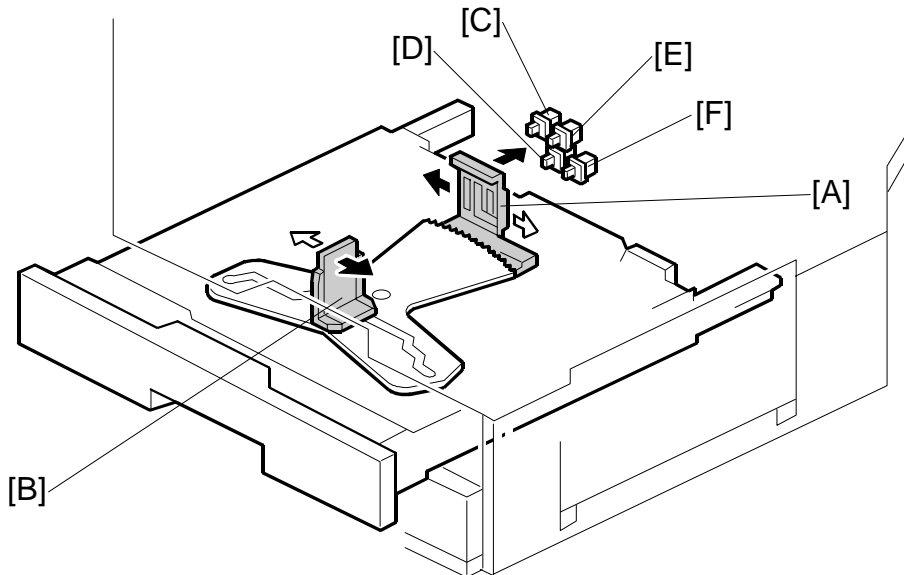

B456D007.WMF

Four paper size switches [C to F] detect paper size. They use the paper tray actuator [A], which is linked with the end plate [B]. The table lists the combinations of switch status and detected paper size.

Models		Switch Location			
North America	Europe/Asia	1 [C]	2 [D]	3 [E]	4 [F]
11" x 17" SEF	11" x 17" SEF	0	0	1	0
A3 SEF	A3 SEF	0	1	0	1
8 1/2" x 14" SEF	B4 SEF	1	0	1	1
8 1/2" x 11" SEF	A4 SEF	0	1	1	0
8 1/2" x 11" LEF	8 1/2" x 11" LEF	1	1	0	1
A4 LEF	A4 LEF	1	0	1	0
B5 LEF	B5 LEF	0	1	0	0
5 1/2" x 8 1/2" LEF	5 1/2" x 8 1/2" LEF	1	0	0	0

1: Pushed, 0: Not pushed

- NOTE:** 1) Other paper sizes cannot be automatically detected. The user must select them at the operation panel with a user tool.  
 2) The machine disables feed from a tray if the paper size cannot be detected (when the paper size actuator is broken or no tray is installed).

## 2.5 REVERSE ROLLER AND PICK-UP ROLLER RELEASE

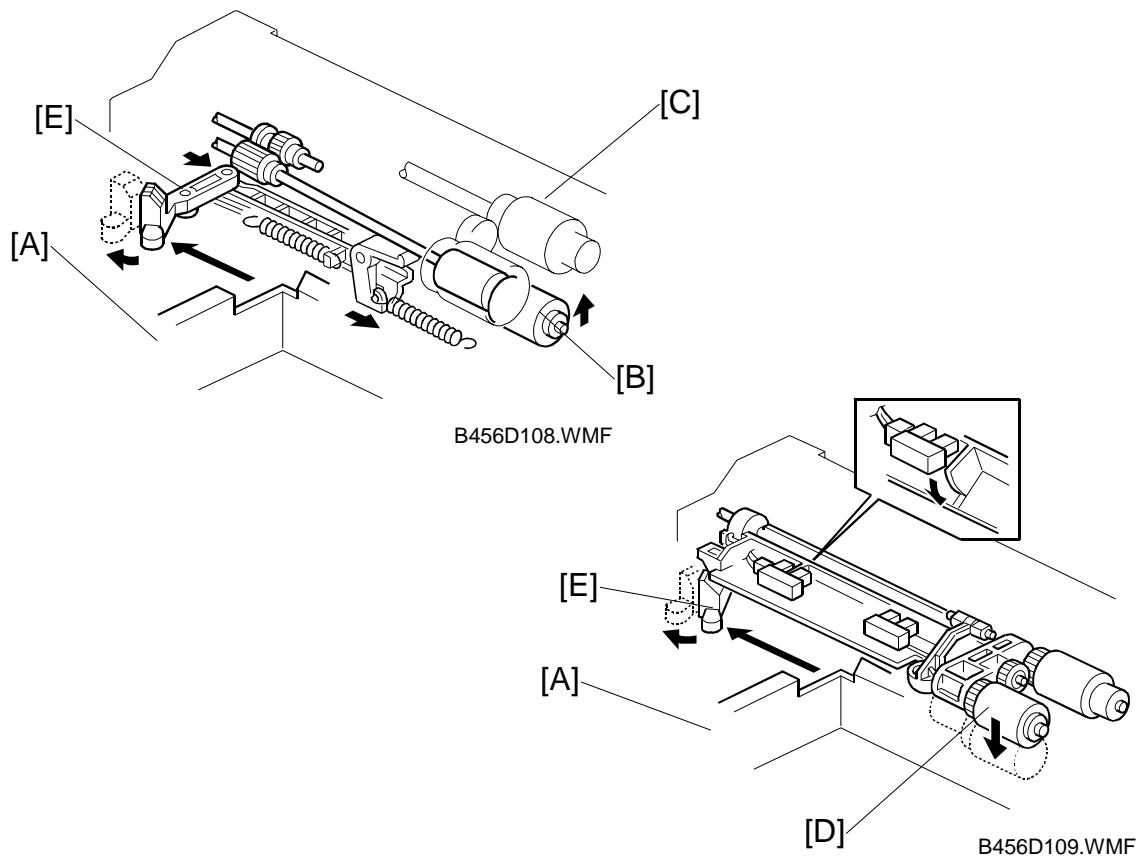

The pickup roller and separation roller release the paper when it is not being fed. This helps remove jammed paper easily.

When the paper tray [A] is not in the machine, the separation roller [B] is away from the paper feed roller [C] and the pickup roller stays in its upper position.

When the paper tray is pushed into the machine, it pushes the release lever [E]. This causes the pickup roller [D] to go down into contact with the top sheet of paper, and causes the reverse roller [B] to move up and contact the paper feed roller.

## 2.6 PAPER LIFT

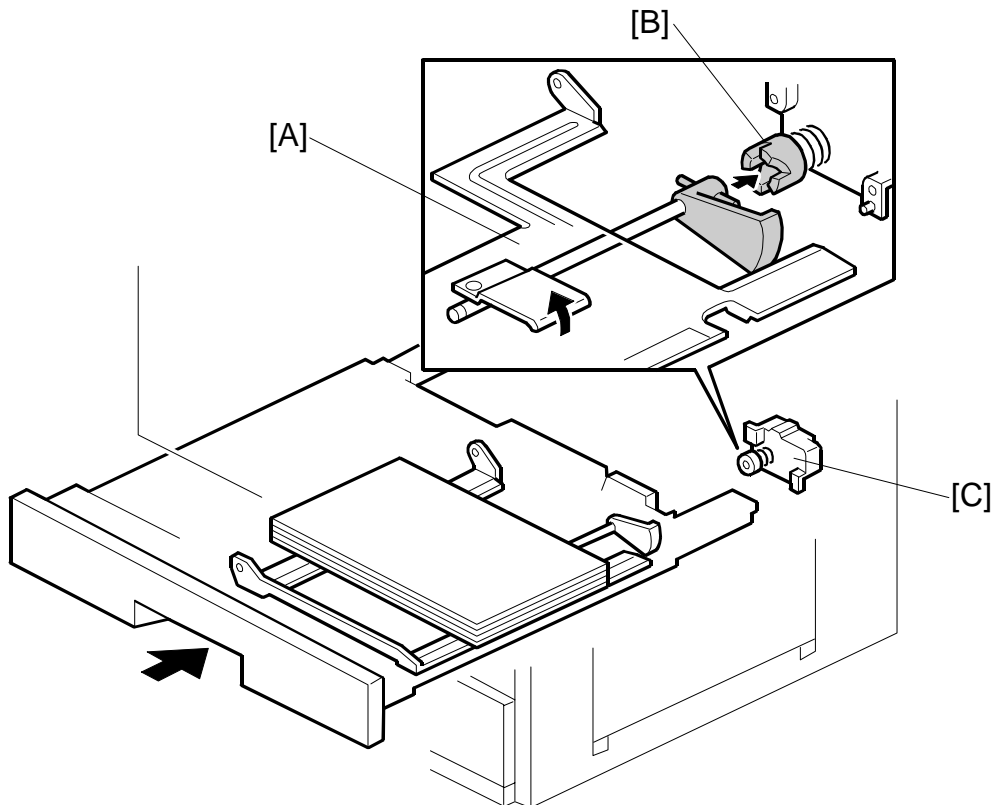

B456D005.WMF

The tray lift motor [C] raises/lowers the tray bottom plate [A] (via the coupling gear [B]), based on the signals from the paper size switches, paper end sensor, and upper limit sensor.

The motor starts to lift the plate when all of the following three conditions exist: any of the paper size switches is pushed, the paper end sensor actuator is in the sensor, and the upper limit sensor actuator is out of the sensor. The motor stops lifting the plate when the upper limit sensor actuator enters the sensor.

## 2.7 PAPER HEIGHT AND END DETECTION

### *Paper Height Detection*

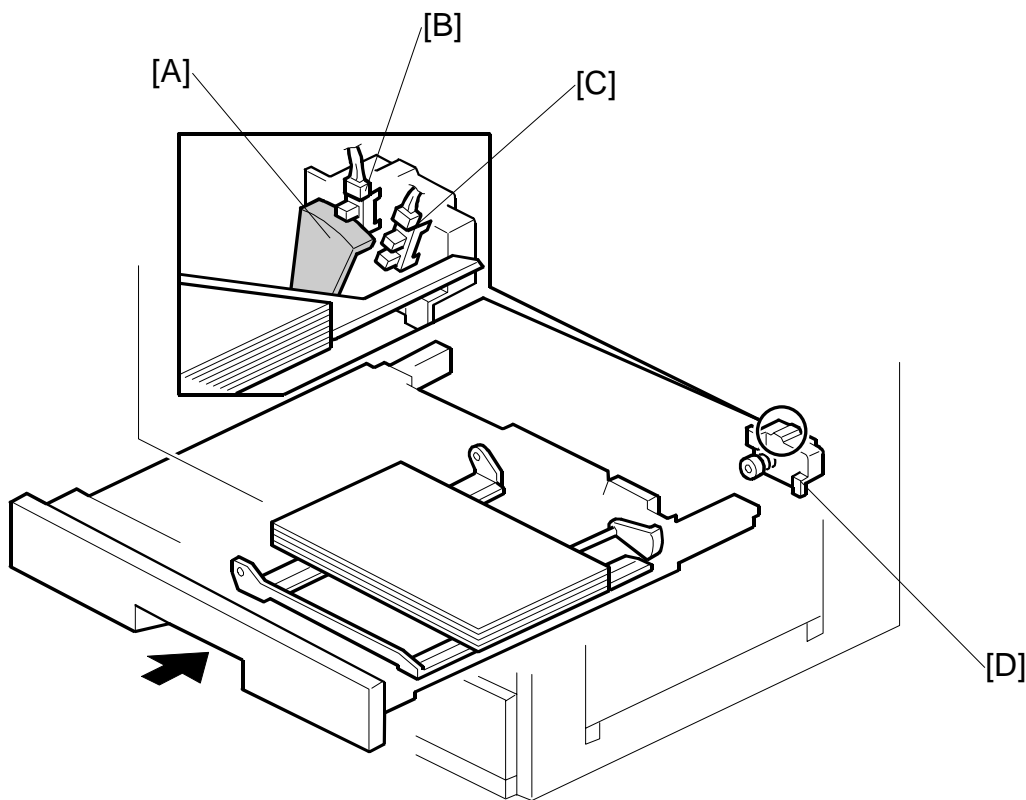

B456D006.WMF

Two paper height sensors detect the amount of paper in the tray. The actuator [A] on the lift arm shaft [D] turns counterclockwise, passing through the paper height sensor 2 [C] and the paper height sensor 1 [B].

Remaining paper	Paper height sensor 2 [C]	Paper height sensor 1 [B]
Full	ON	ON
Nearly full	OFF	ON
Near end	OFF	OFF

On: Actuator inside sensor, Off: Actuator not inside sensor

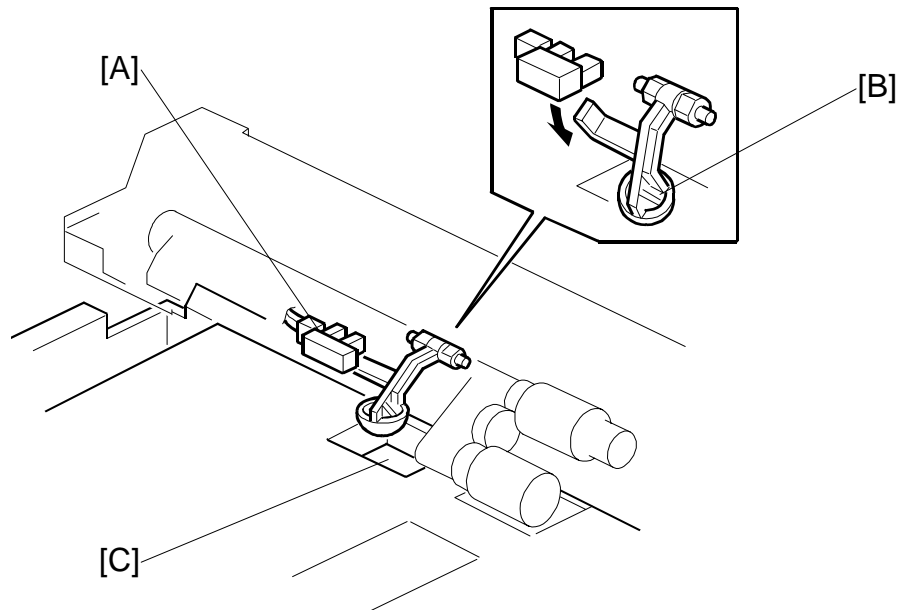
**Paper End and Bottom Plate**

B456D106.WMF

The paper end sensor [A] detects paper end. When the paper is all used, the paper end sensor feeler [B] drops into the cutout [C] in the tray bottom plate.

When paper end is detected, the tray lift motor (● 2.6) lowers the bottom plate.